



Metal/Stone BarnCam Instructions

Important Safety Precautions

- To prevent fire or shock hazard, do not expose this product to rain or water. Do not use near a bath tub, wash bowl, sink, or laundry tub; do not use in a wet basement or in or around a swimming pool.
- To avoid electrical shock, do not open the case of this product.
- Operate this product using only the power supply included with it.
- Do not overload electrical outlets or extension cords as this can result in fire or electric shock.
- Refer servicing to qualified personnel only.

CAUTION:

Changes or modifications not expressly approved by the seller could void the user's warranty and create an extreme hazard.

NOTE:

This equipment has been tested and found to comply with the limits for Class B digital device, pursuant to part 15 of the FCC rules. These limits are designed to provide reasonable protection against harmful interference in a residential installation. This equipment generates, uses and can radiate radio frequency energy and, if not installed and used in accordance with the instructions, may cause harmful interference to radio communications. However, there is no guarantee that interference will not occur in a particular installation. If this equipment does cause harmful interference to radio or television reception, which can be determined by turning the equipment off and on, the user is encouraged to try to correct the interference by one or more of the following measures:

- Reorient or relocate the receiving antenna.
- Increase the separation between the equipment and receiver.
- Connect the equipment into an outlet on a circuit different from that to which the receiver is connected.
- Consult the seller/dealer or an experienced radio/TV technician for help.

Camera Setup Instructions



Here is your camera and transmitter.
(Actual camera may vary.)



Here is your receiver.

This kit is made up of three main parts. Part one is the camera, power adapter, mounting hardware and cable. Part two is the transmitter and power adapter. Part three is the receiver, power adapter and cables.

Your Camera system was thoroughly tested prior to shipment. Please set everything up inside your house before installing outside to ensure nothing was damaged during shipment.

Step One: Mount the camera in a good location to view your animals. You can adjust the angle of the camera to position the camera into place. Run the cables from the camera to the outside of the barn where the transmitter will be mounted.

Step Two: Mount the transmitter on the outside of your barn with the label side facing your house. Try to mount it so that there is a direct line of sight to where you will be viewing your camera on your TV. The set screw on the bracket is adjustable. Make sure it is tightened to the proper position. The wires coming out of the transmitter should not point up. The power supply should be plugged into the red connector and then plugged into an outlet inside your barn. Your camera system came to you completely assembled.

If you disconnect the wires during installation, please make sure they are re-connected correctly

Connect the wires from your camera to the other two colored jacks coming out of the transmitter. Yellow to Yellow, White to White. Please make sure that the power supplies connected to the camera and transmitter both say Clover and that the one that says 250ma is connected to the camera, the 500ma to the transmitter.

Step Three: Set up the receiver by flipping up the antenna and facing the side with holes to the transmitter. It does not turn 360 degrees so be careful not to break it. Plug in the power supply to the back of the receiver. You can adjust the camera number by pressing the channel button. Your first camera will be set to one, and so on.



You can hook the receiver up to your TV with either the RCA cables (the three colored cables) or the coaxial cable (thick black cable). They are both offered as an option. Do not plug in both as it will not work.

If you use the coaxial cable screw it to the back of the receiver and to your TV. Make sure the switch on the side of your receiver is set to the same channel on which you want to watch your BarnCam (3 or 4).

If you use the RCA cables, you might have to change the inputs on your TV or VCR to get the signal to show on your TV. If you have problems with this please refer to your TV or VCR owner's manual.

Setup tips on next page >>>

Setup Tips

- 1.) Make sure you've ordered the right system for your situation. A wooden barn covered in metal needs the metal barn system.
- 2.) Make sure you have set it up completely in your house first. All of our systems are tested before they are shipped.
- 3.) If it does not work in the house, you should check to make sure your TV is set up correctly. Often there is a video/cable button that needs to be changed to view the signal instead of the cable feed. Please connect it directly to the TV rather than through a VCR during testing.
- 4.) If it does not work in the house, first check that everything is plugged in and the receiver is turned on. The system for metal barns has three power supplies. Two come labeled when shipped (the camera and the transmitter). The third is for the receiver. Make sure that the 250ma power supply is connected to the camera and the 500ma to the transmitter.
- 5.) If it works well in the house but not between the barn and the house, then usually something between the two is causing the problem, or they are not aimed properly. The receiver (and transmitter for wooden barn) should have the pock marked sides facing each other. The system for metal barns should have the BarnCams label facing the house.
- 6.) The signal will pass through walls, but transmits better through windows. Moving the receiver to a window facing the barn might make all the difference.
- 7.) If you have followed these instructions carefully and your system does not work, please give us a call or email. Satisfaction guaranteed!

(920) 474-7776 support@BarnCams.com

TROUBLE SHOOTING

Problems	Cause and remedies	
	Receiver	Camera
No power or No picture/sound	AC adaptor not plugged in Improper TV or Monitor connection	AC adaptor not plugged in
Poor reception	Improper antenna direction Improper channel switching	Antenna direction
Normal sound, dim picture, picture too bright/dark	Improper brightness control setting on your TV/monitor	Lighting source in the field of view
Picture rolls and jumps, scrambled picture	Improper V-hold control setting on your TV / monitor	Other 2.4 GHZ transmitter wireless phone/network

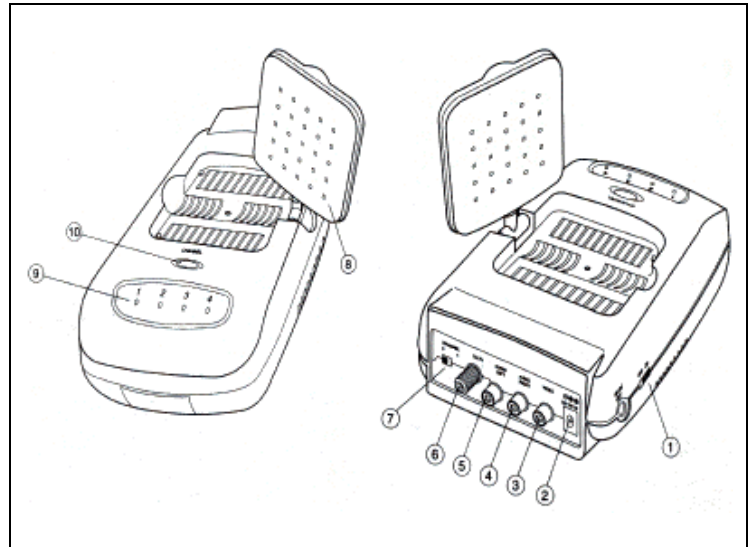

<p>1. POWER ON/OFF SWITCH Switch for the power on/off.</p>	<p>6. TV COAXIAL CONNECTOR RF jack for connecting the wall antenna terminal.</p>
<p>2. DC IN Plug in the 12 volt adaptor (supplied).</p>	<p>7. TV CHANNEL SELECTOR Select the receiving channel 3 or 4 on your TV.</p>
<p>3. VIDEO OUT JACK RCA video out jack for operation.</p>	<p>8. DIRECTIONAL 2.4 GHZ ANTENNA Receive the audio and video signals.</p>
<p>4. RIGHT AUDIO OUT JACK Right audio out jack for operation with monitor or TV.</p>	<p>9. CHANNEL INDICATOR LIGHTS Must be set to same number on both.</p>
<p>5. LEFT AUDIO OUT JACK Left audio output jack for operation with monitor or TV.</p>	<p>10. CHANNEL SELECTION BUTTON Use to find optimal reception. Must select the same channel on both transmitter and receiver.</p>

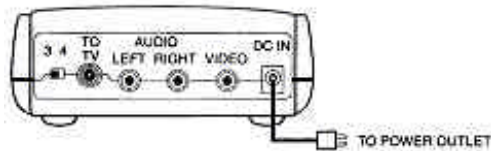

1. Place the wireless receiver unit on or near the TV or monitor where you want to install it.
2. Set the right angle of the flat pitted face of the antenna toward the transmitter's antenna.
3. Connect the supplied 500 ma AC adaptor to the DC IN jack at the rear of the receiver and plug it into 120V AC outlet.
4. Turn on the power switch. The red LED (channel indicator light) on the receiver will indicate that the unit is turned on.

WIRELESS OPERATION

Make sure TV or monitor is turned **on** before using system.

1. Set your TV and VCR to either channel 3 or 4, whichever is better for reception in your area. Be sure to set the wireless receiver to same channel as your TV and VCR.
2. The flat pitted face of the antenna on the receiver should be facing the transmitter to get the best picture and sound.
3. Each home or office has different reception. Different construction products such as foil insulation, heating ducts, steel studs, etc., will create different reception conditions. It may be necessary to set the right angle of the antenna or move the wireless transmitter and wireless receiver to get the best reception. Placing the wireless receiver on a shelf near the TV/monitor or VCR may improve the reception.

Operation With TV

1. If your TV has A/V jacks, connect one set of A/V cables to the TV's A/V jacks and to the A/V jacks on the receiver. Be sure the yellow, red and white plugs match the yellow, red and white jacks on both the TV and the receiver. If the TV has only a single jack for audio input, connect the white plug to that jack.
2. If your TV has only a single coaxial input, connect a length of coaxial cable from it to the output port of the A/B switch (not supplied). Then connect coaxial cable from one of the switch's input ports to the connector labeled TO TV on back of the receiver, and connect your cable TV or antenna input to the switch's other input port. Set the channel 3/4 switch on the back of the receiver whichever channel (3 or 4) is not used by any local TV stations. Then tune the TV to that station.
3. If using an A/B switch (not supplied), select between viewing the BarnCam reception and the cable antenna signal on the TV by moving the switch either to A or B.
4. Make sure the ON/OFF switch is in the ON position. Plug one end of the receiver's power adaptor into the back of the receiver and the other end into any 120 V wall outlet. Use only the adaptor provided.
5. Locate and orient the receiver according to the Setup instructions in this manual.

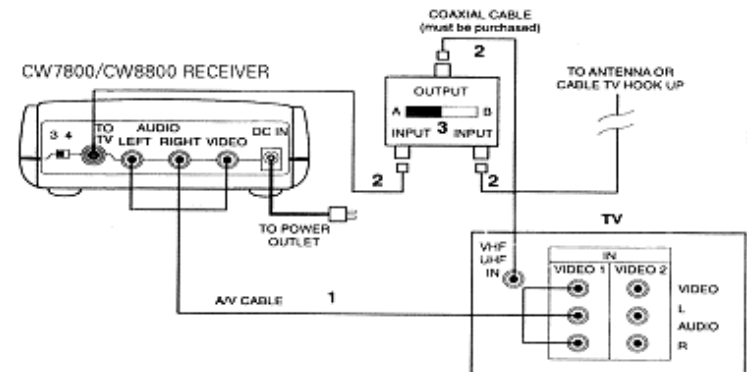

Operation With TV & VCR

This setup enables you to record transmitted audio and video on your remote VCR and also enjoy the picture and sound on a remote TV. Refer to your VCR's manual for specific recording instructions.

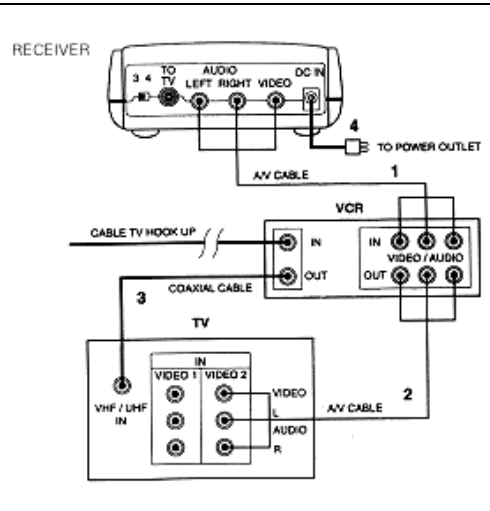

1. Connect one set of audio/video (A/V) cables to the A/V jacks of the receiver and to the jacks on your VCR labeled LINE IN. Be sure the yellow, red and white plugs match the yellow, red and white jacks on both the receiver and the VCR. If the VCR has only a single jack for audio input, connect the white plug to it.

2. If your TV has A/V input jacks, connect another set of A/V cables (not supplied) to the TV's A/V jacks and to the jacks on your VCR labeled LINE OUT.

3. If your TV has only a single coaxial input port, connect a length of coaxial cable from the TV's VHF/UHF IN coaxial connector to the OUT coaxial connector on your VCR. To watch cable channels on that TV, connect your cable TV hookup to the IN coaxial connector on your VCR.

4. Make sure the ON/OFF switch is in the ON position. Plug one end of the receiver's power adaptor into the back of the receiver and the other end into any 120V wall outlet. Use only the adaptor provided.

5. Locate and orient the receiver according to the Setup instructions in this manual.

Operation With Monitor

1. Connect one set of A/V cables to the monitor's A/V jacks and to the A/V jacks on the receiver.
2. Be sure the yellow, red and white plugs match the yellow, red and white jacks on both the monitor and the receiver. If the monitor has only a single jack for audio input, connect the white plug to that jack.
3. Be sure the monitor, the wireless camera and the receiver are turned **on**.

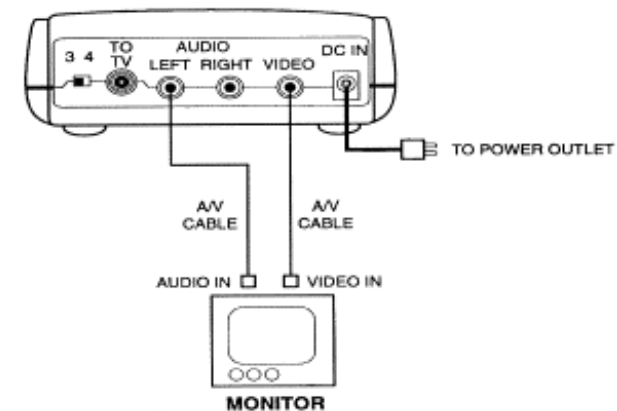

Operation With Monitor & VCR

1. Connect one set of A/V cables to the VCR's A/V jacks (IN) and to the A/V jacks on the receiver.
2. Be sure the yellow, red and white plugs match the yellow, red and white jacks on both the VCR (IN) and the receiver. If the VCR has only a single jack for audio input, connect the white plug to that jack.
3. Connect the A/V cable (not supplied) to your VCR OUT jack. Plug one plug into the VIDEO OUT jack and the other plug into the AUDIO OUT jack on your VCR.
4. Plug the other ends into the VIDEO IN jack and AUDIO IN jack on your monitor.
5. Be sure the monitor, the wireless camera and the receiver are turned **on**.

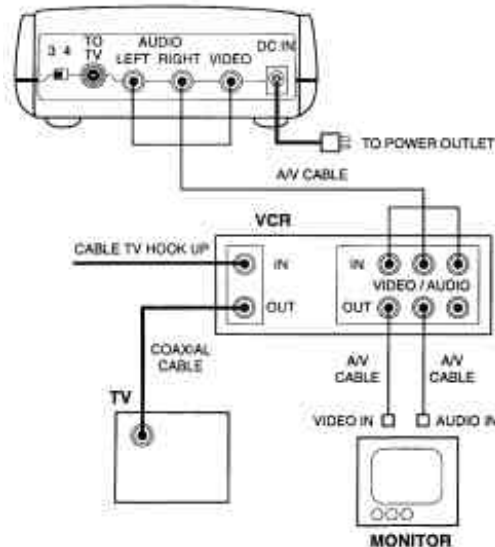

Warranty

This warranty gives the original purchaser specific legal rights. The original purchaser may also have other rights which vary from state to state.

If products do not function because of any defect in material or workmanship, they will be repaired free for a period of one year on labor and parts from the date of original purchase. This warranty does not cover modification, abuse, or neglect. This warranty does not cover incidental or consequential damages unless the state of owner's residence specifically prohibits limitations on incidental or consequential damages.

How to Obtain Service Within Warranty

Please pack unit carefully and safely and send it prepaid by insured parcel post to:

Saddlebrook BarnCams LLC
N76 W36096 Saddlebrook Lane
Oconomowoc, WI 53066 USA

Please include a note explaining how the unit is defective.

We will repair or replace and return to owner all units under this limited warranty.

How to Obtain Service After Warranty Expiration

Follow the instructions for "Service Within Warranty" and include a check for \$20 to cover the costs of return postage and handling. Include your e-mail address for faster and more accurate communication. An estimate of the repair/replacement cost will be sent for advance approval.

**If you have any questions or need
additional help please e-mail:**

support@BarnCams.com

or call: (920)474-7776

**Saddlebrook BarnCams LLC
N76 W36096 Saddlebrook Lane
Oconomowoc, WI 53066**